

ANEXO B - 1

Ilustrações

Pontes do Rio Tietê



Figura B.1 - Ponte Andrade / Pereira Barreto



Figura B.2 - Ponte SP-463 (Araçatuba / Auriflamma)

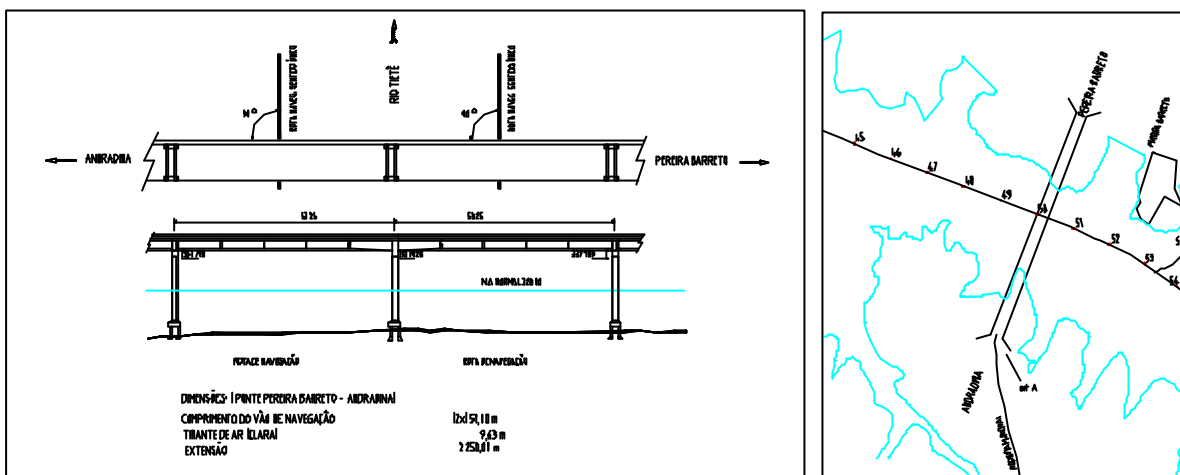

Figura B.3 - Ponte SP-425 (Penápolis / São José do Rio Preto)

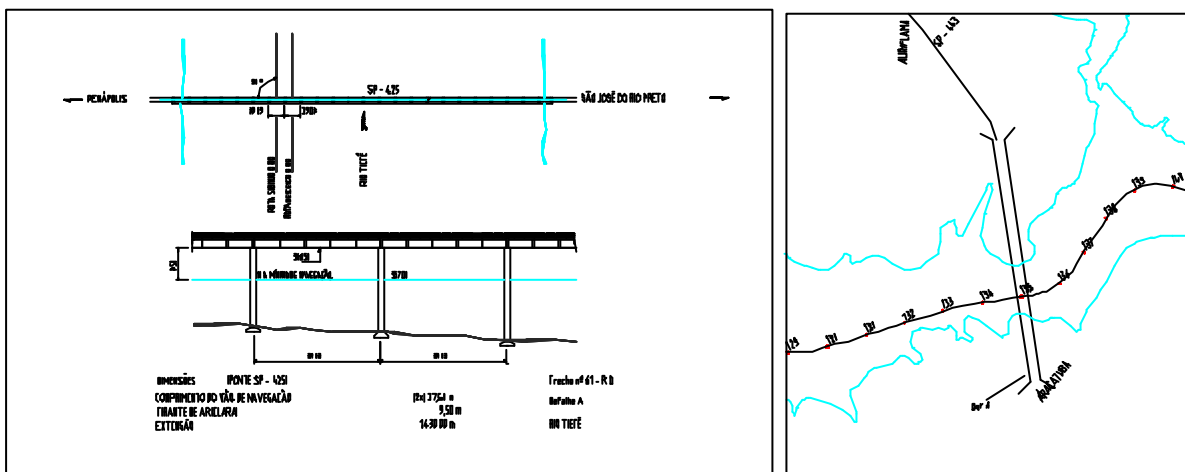

Figura B.4 - Ponte SP-333 (Cafelândia / Borborema)

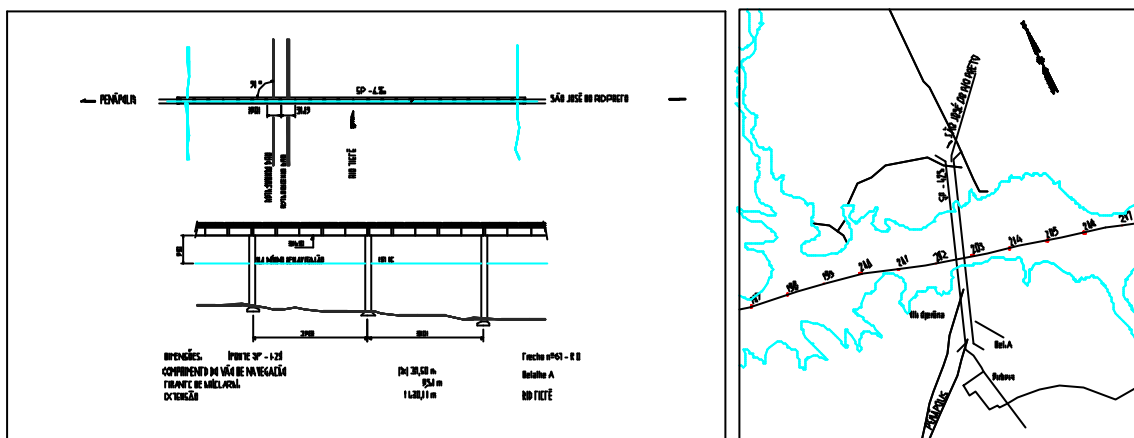

Figura B.5 - Ponte BR-153 (Promissão / Ubarana)

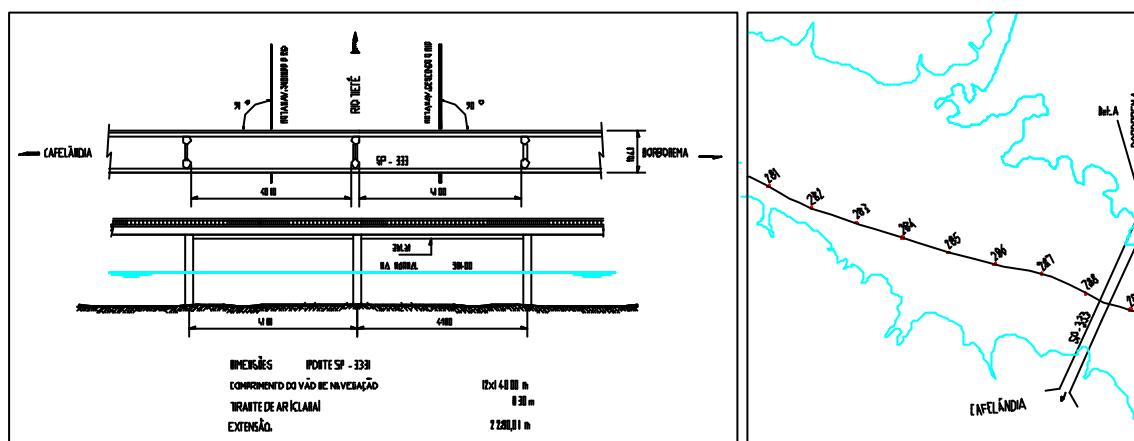

Figura B.6 - Ponte SP-225 (Pederneiras / Jaú)

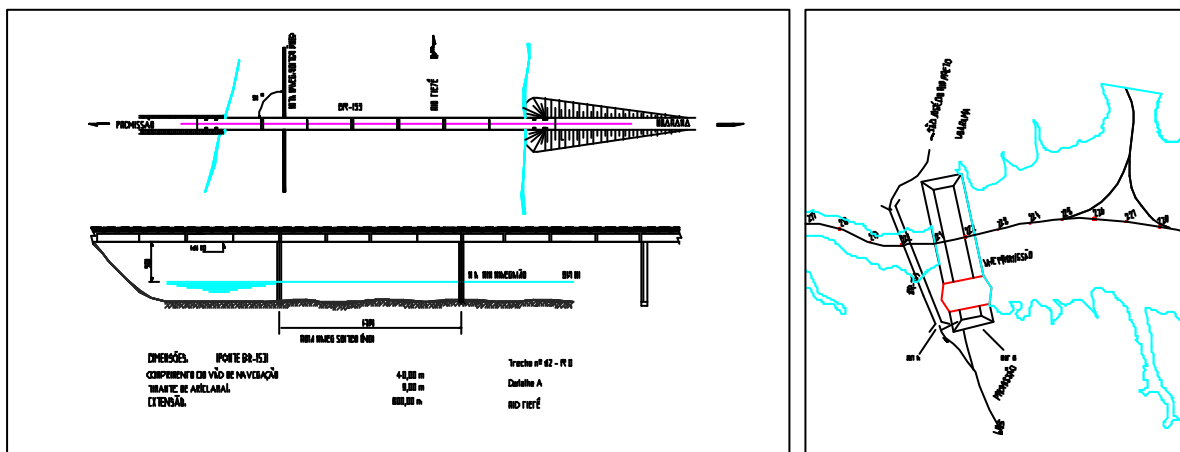

Figura B.7 - Ponte SP-191 (São Manuel / Santa Maria da Serra)

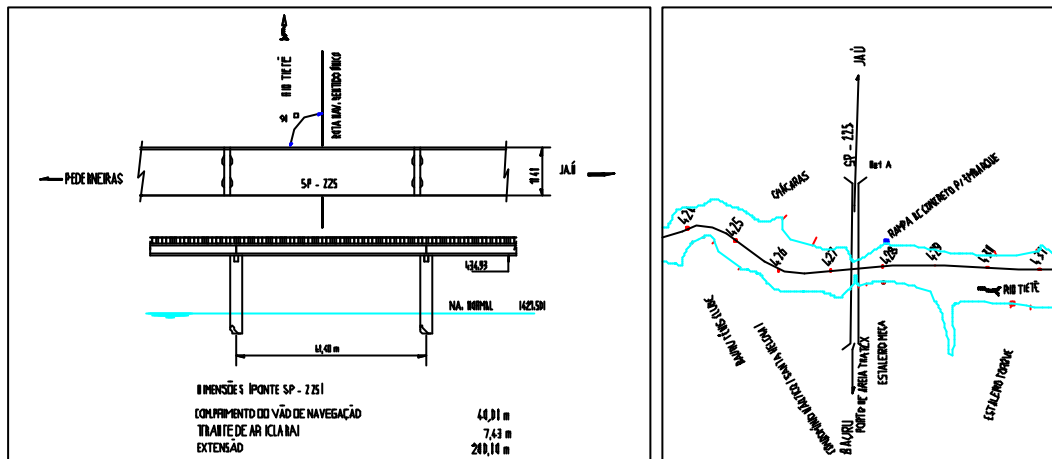

Figura B.8 - Ponte SP-461 (Birigüi / Buritama)

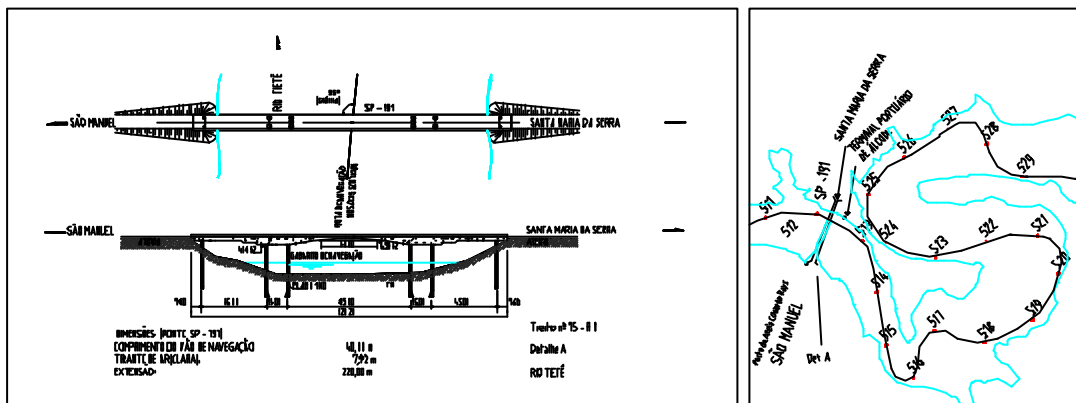

Figura B.9 - Ponte SP-147 (Botucatu / Piracicaba)

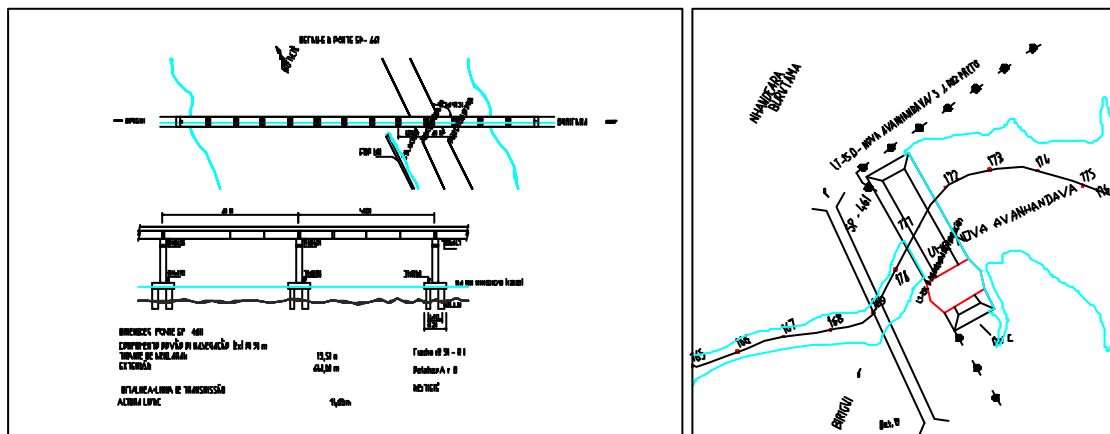

Figura B.10 - Ponte SP-595 (Ilha Solteira / Andradina)

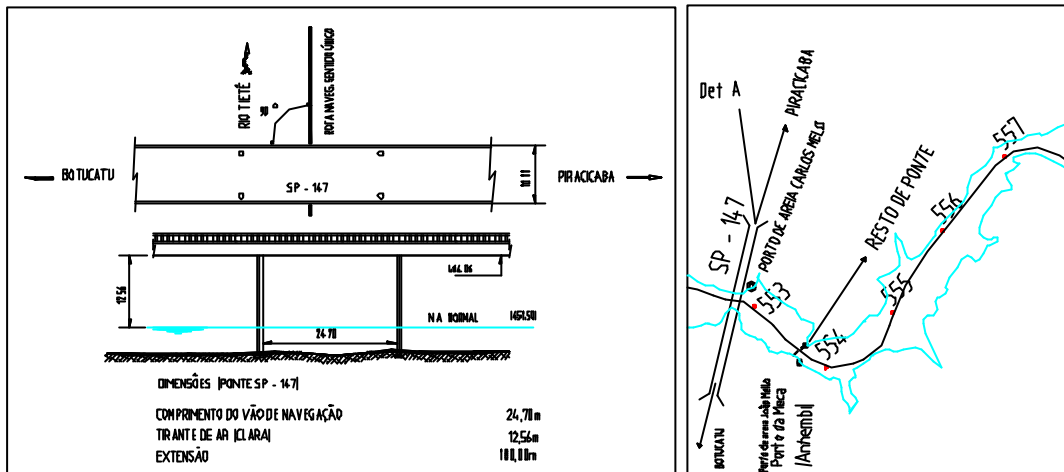

Figura B.13 - Ponte SP-310 (Pereira Barreto / Auriflama)

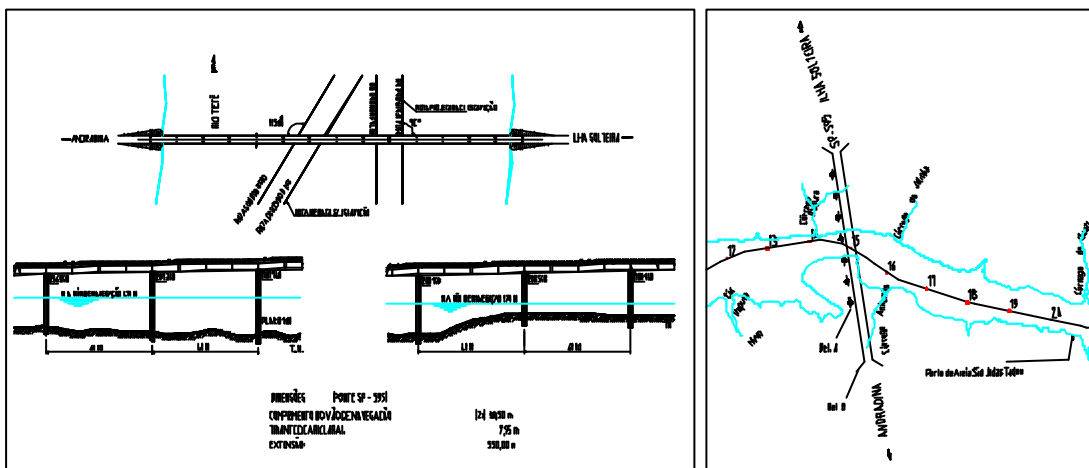

Figura B.14 – Pontes dos Rios Tietê e São José dos Dourados

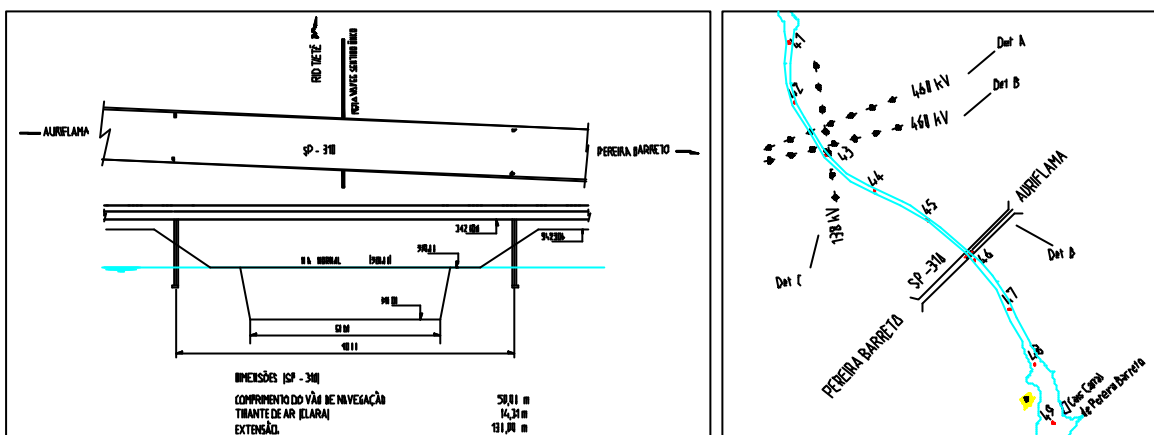

Figura B.18 - Ponte SP-270(SP) / BR-267(MS) (Presidente Epitácio / Bataguassu)

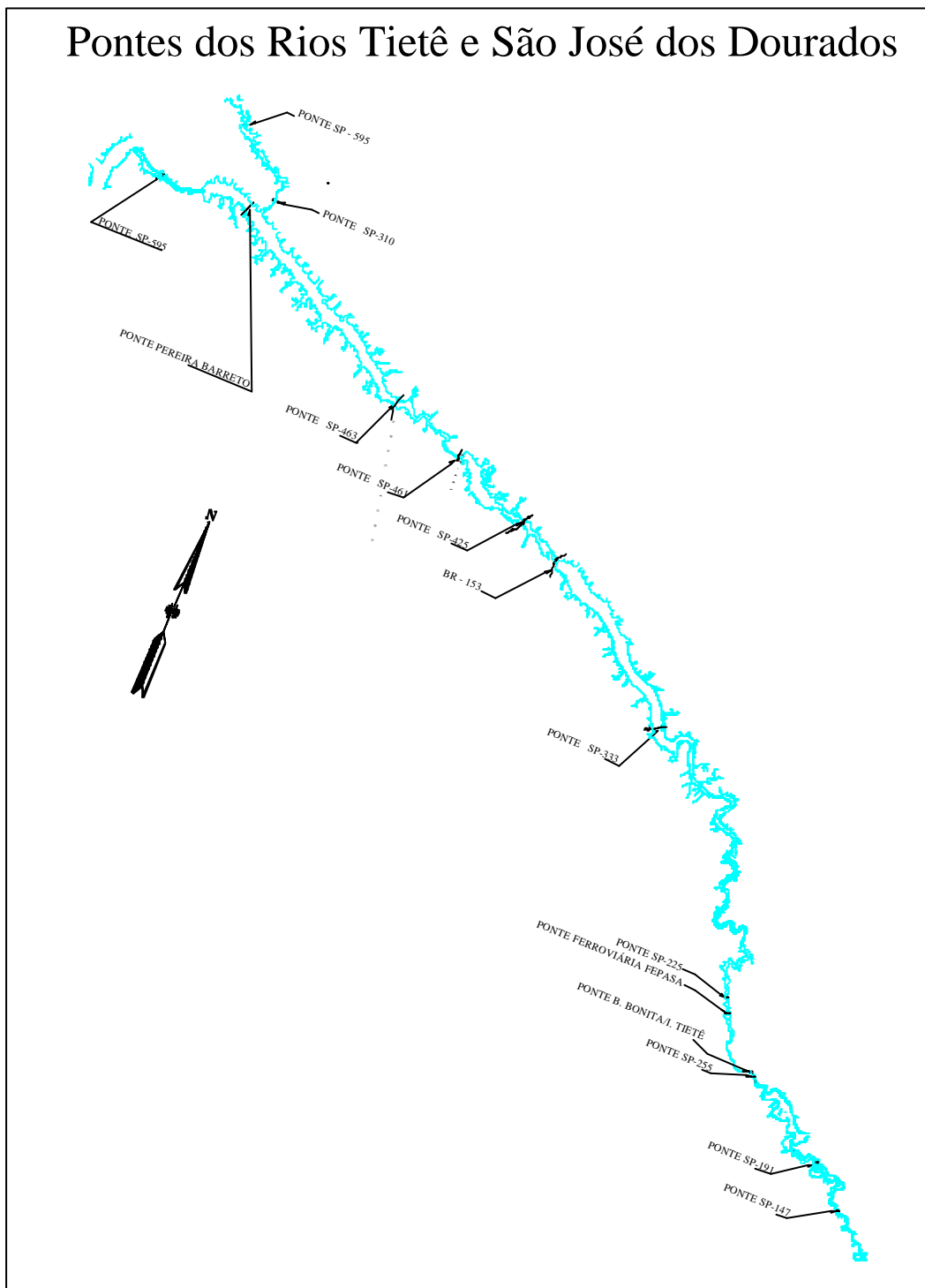

Figura B.19 - Ponte Ferroviária (Três Lagoas / Castilho)

Pontes do Rio Paranaíba

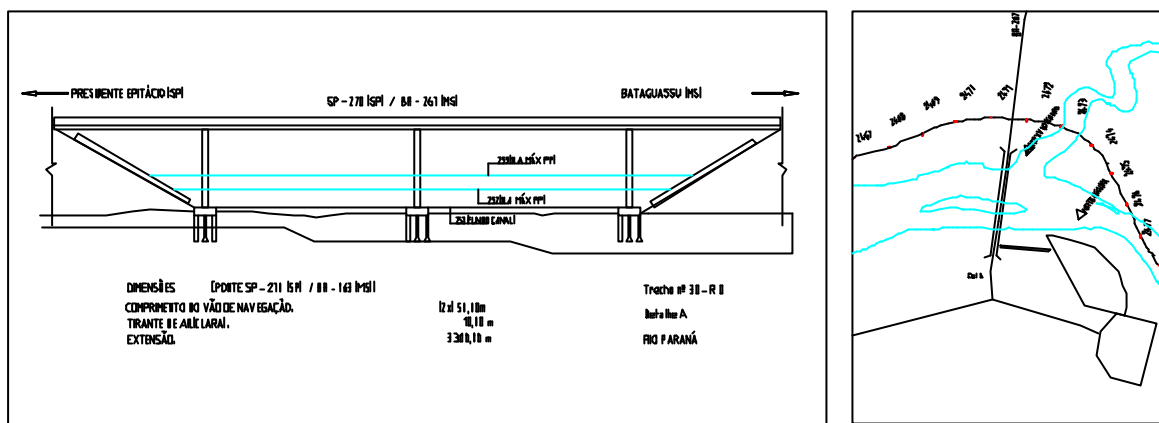

Figura B.20 - Ponte Br-497/Ms-240 (Paranaíba/Carneirinho)

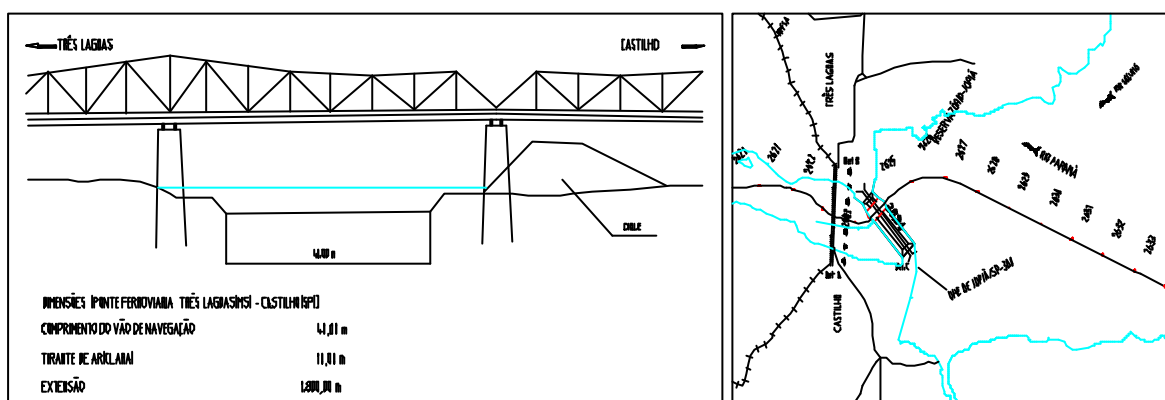

Figura B.21 - Ponte BR-365/BR-364 (Santa Vitória/São Simão)

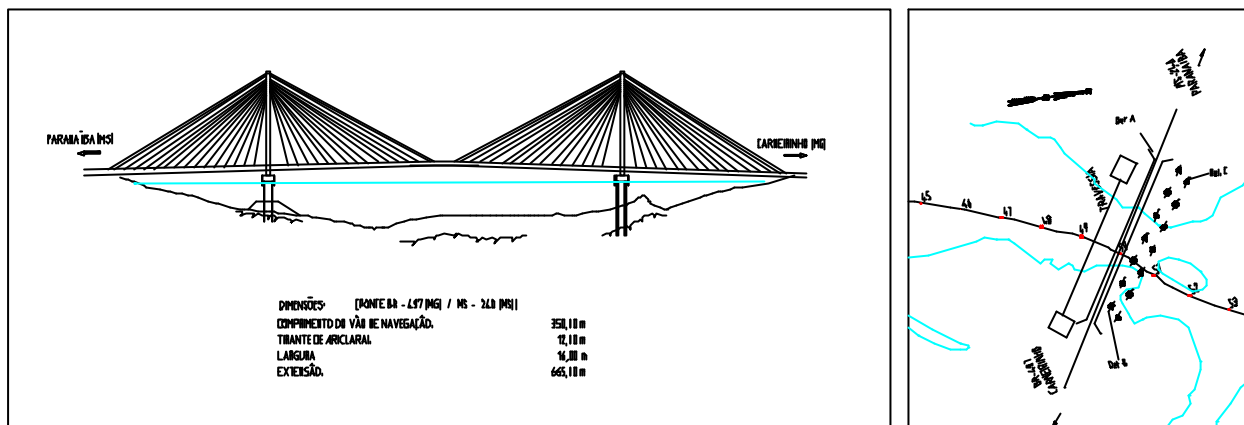

Figura B.22 – Pontes dos Rios Paraná e Paranaíba

Eclusas do Rio Tietê

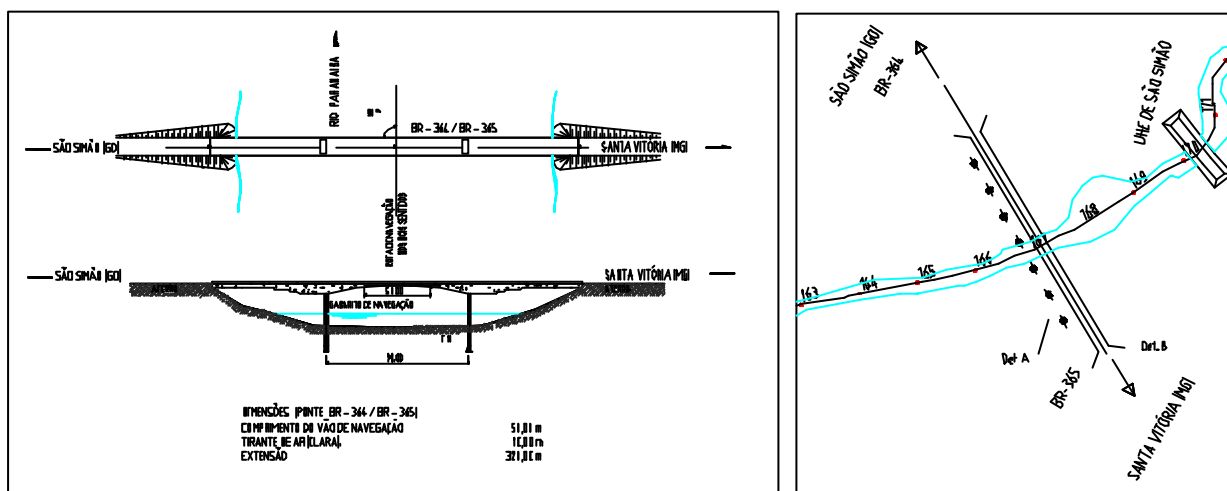

Figura B.23 - Eclusa de Barra Bonita

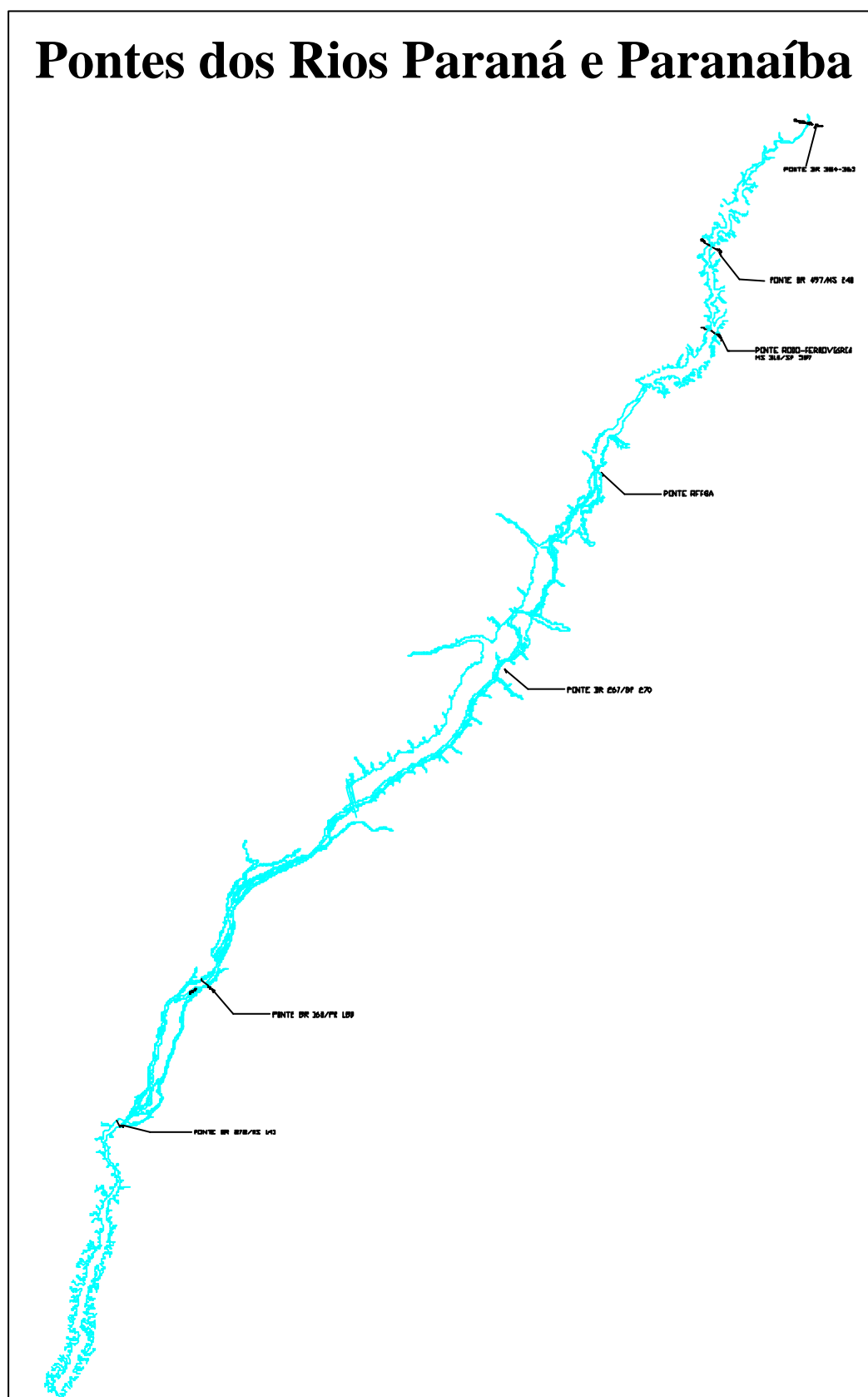

Figura B.24 - Eclusa de Bariri

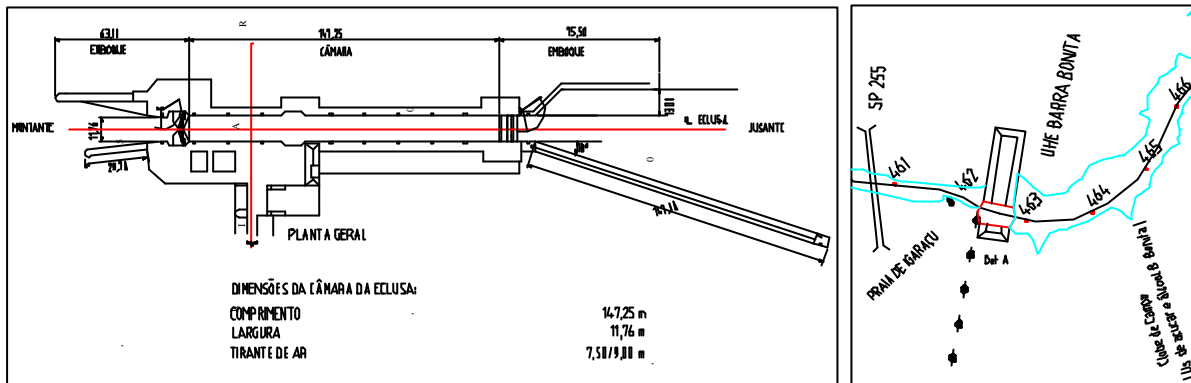

Figura B.25 - Eclusa de Ibitinga

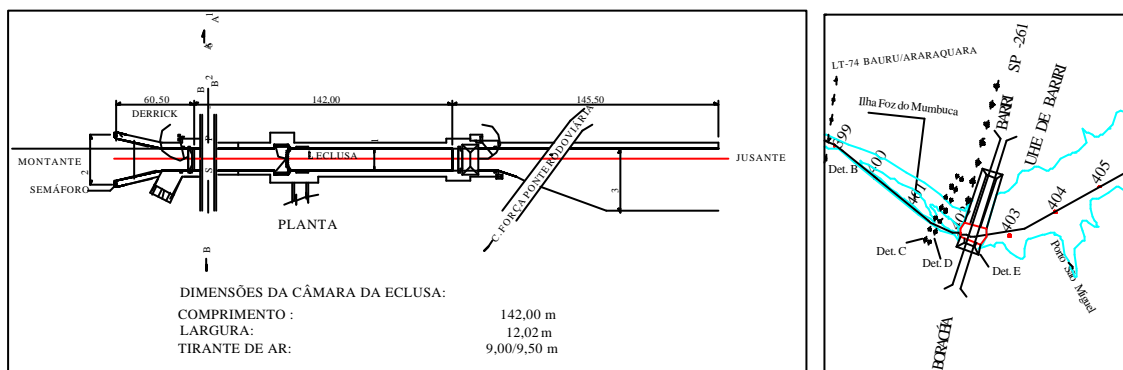

Figura B.26 - Eclusa de Promissão

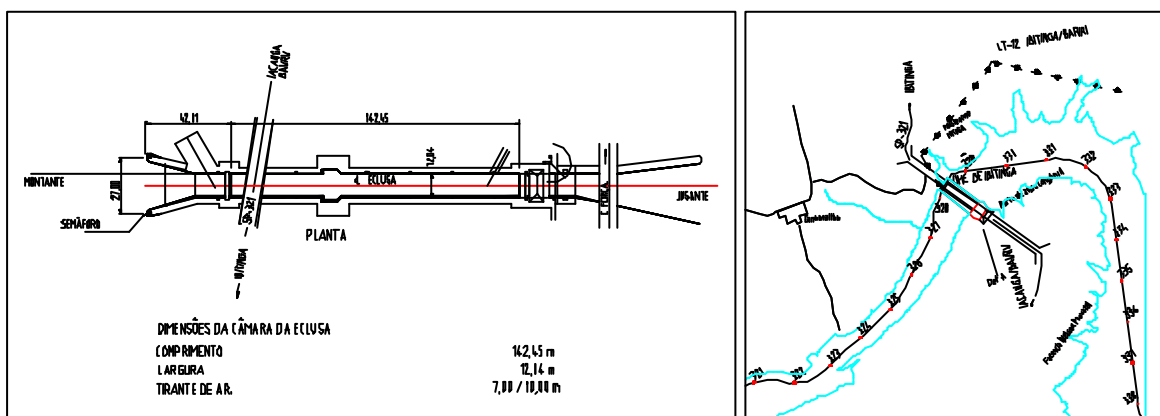

Figura B.27 - Eclusas de Nova Avanhandava

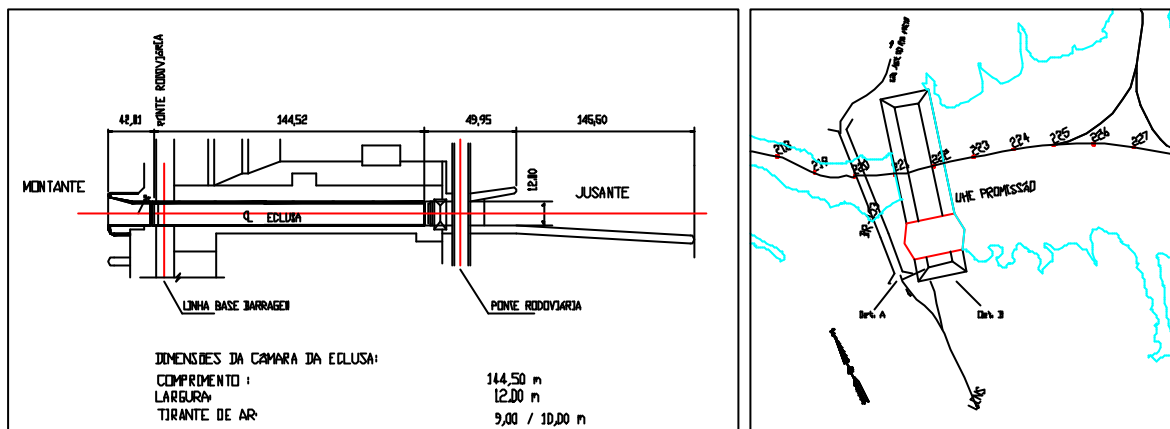

Figura B.28 - Eclusas de Três Irmãos

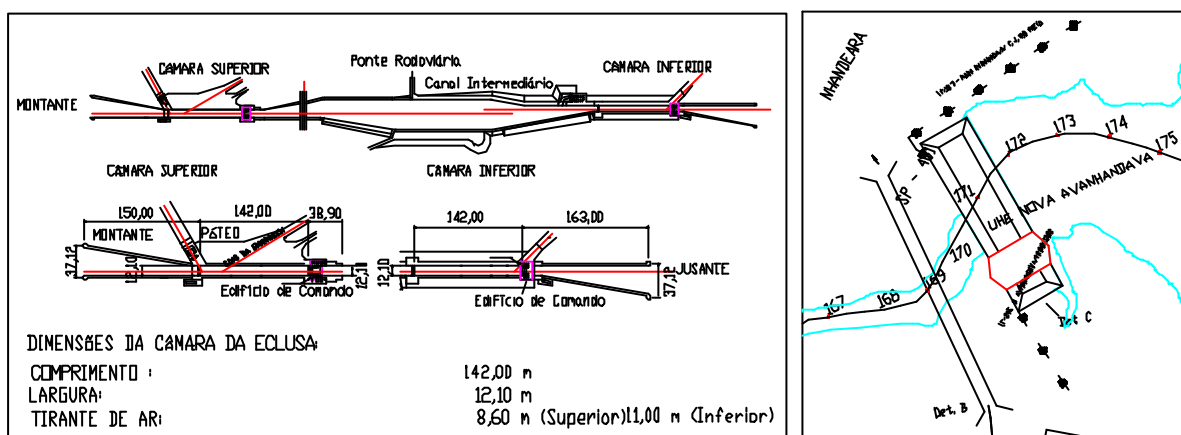

Figura B.29 – Eclusas do Rio Tietê

Eclusas do Rio Paraná

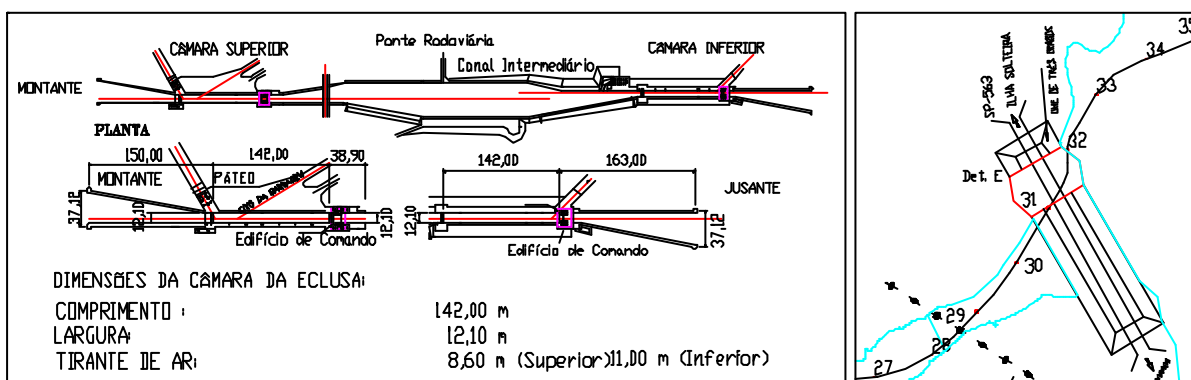

Figura B.30 - Eclusa de Jupia

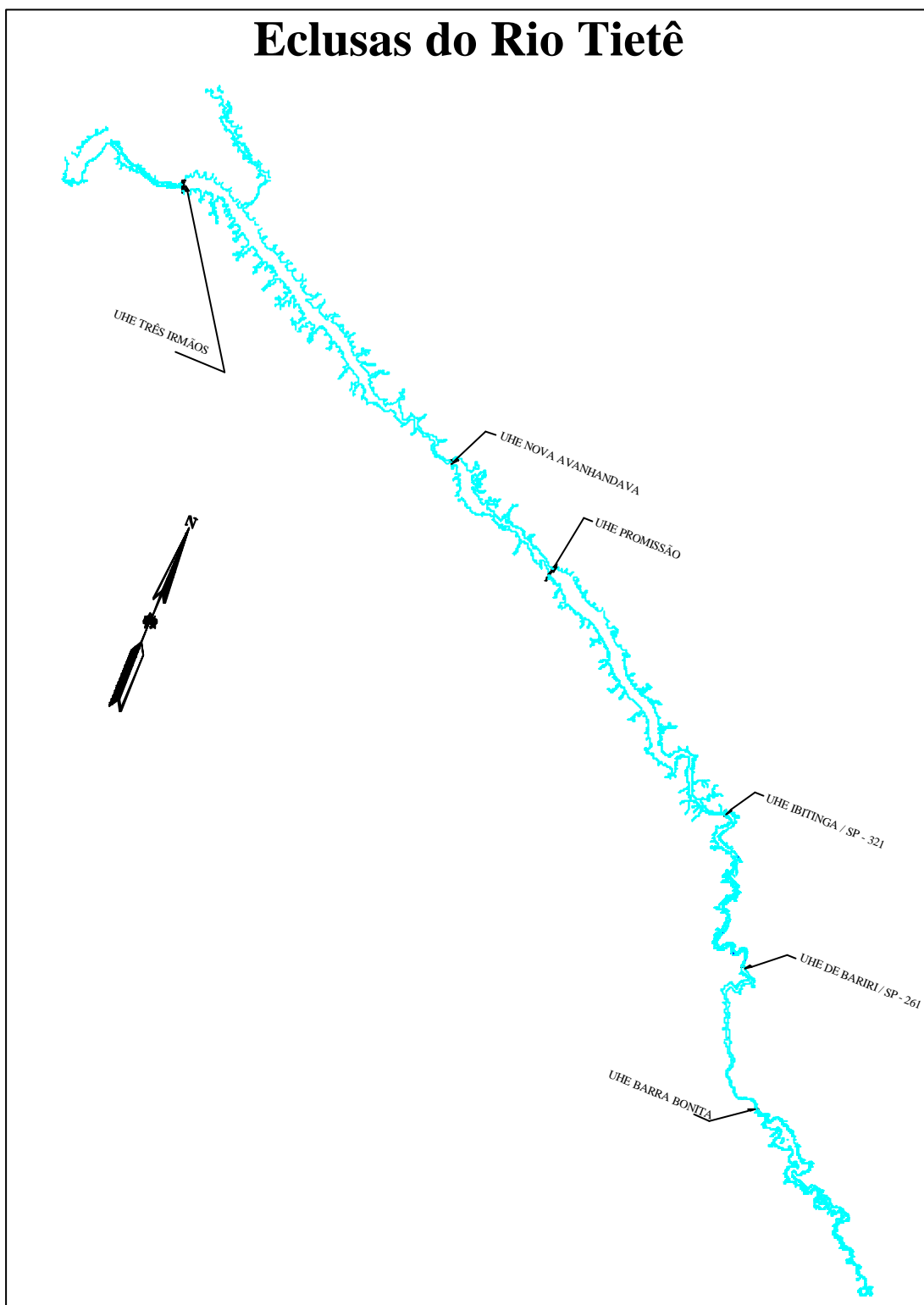

Figura B.31 - Eclusa de Primavera

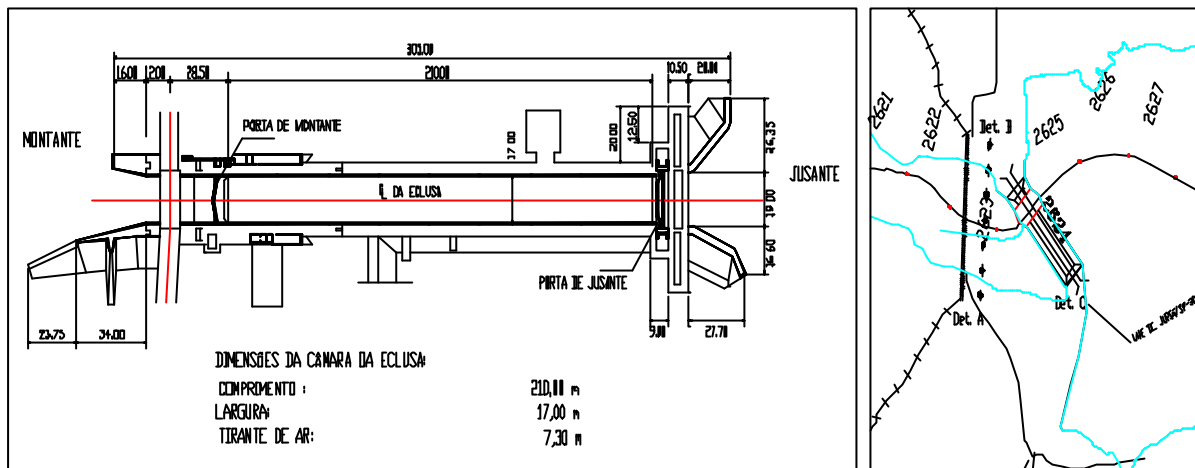

Figura B.32 – Eclusas do Rio Paraná

Raios de Curvatura do Rio Tietê

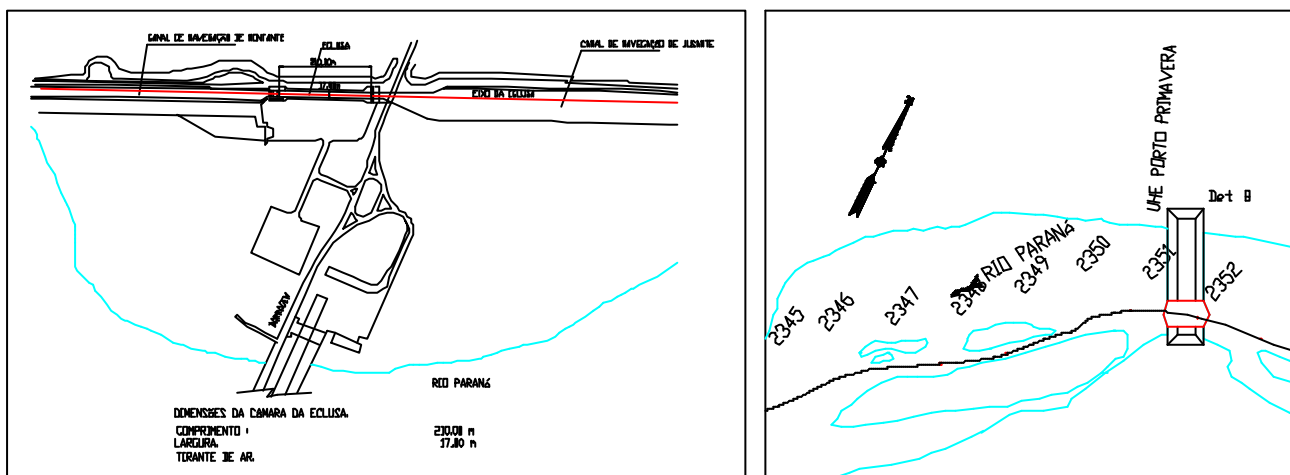

Figura B.33 – Raios de Curvatura dos Pontos Kilométricos 143-145, 147-149 e 158-159

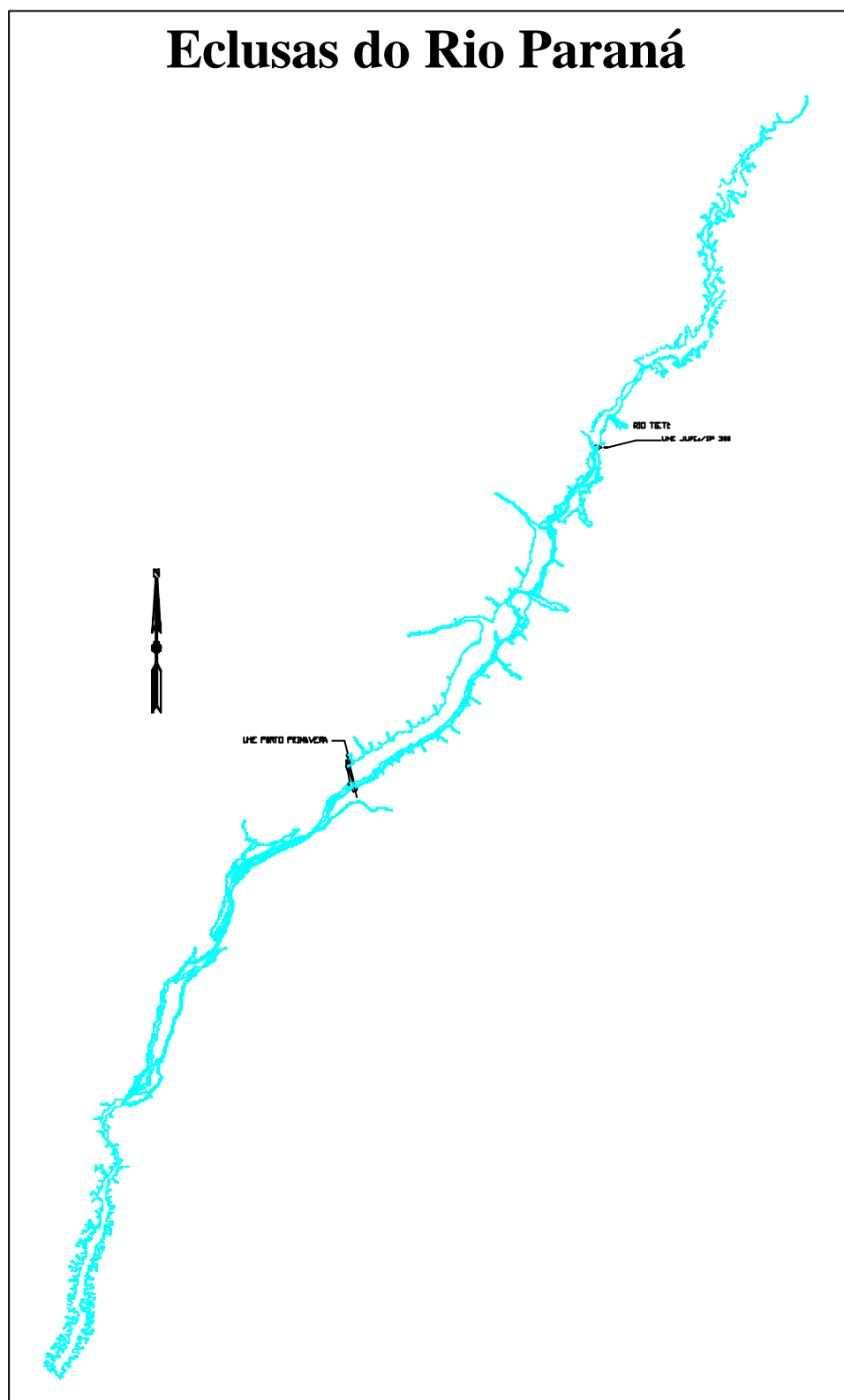

Figura B.34 – Raios de Curvatura dos Pontos Kilométricos 161-163, 331-333 e 338-340

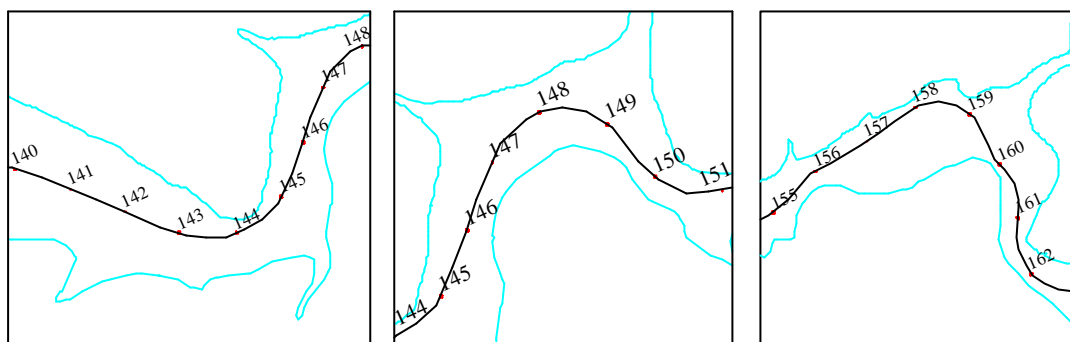

Figura B.35 – Raios de Curvatura dos Pontos Kilométricos 352-354, 354-357 e 381-385

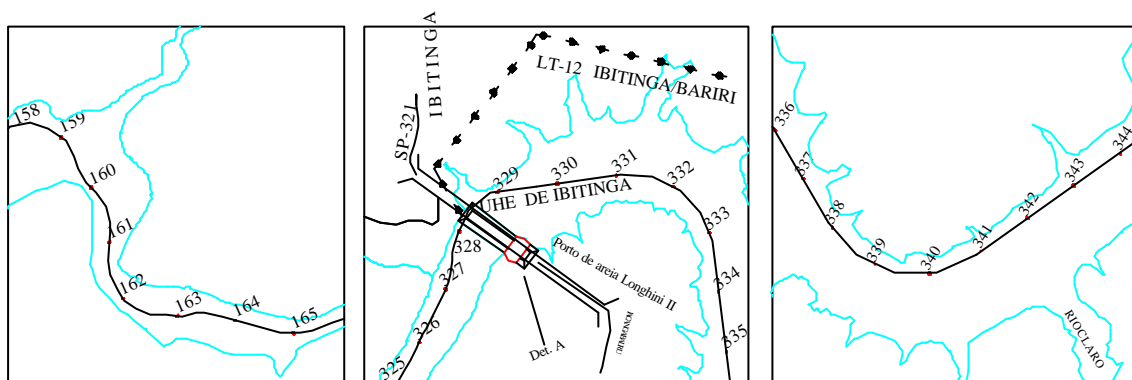

Figura B.36 – Raios de Curvatura dos Pontos Kilométricos 387-389, 391-392 e 394-396

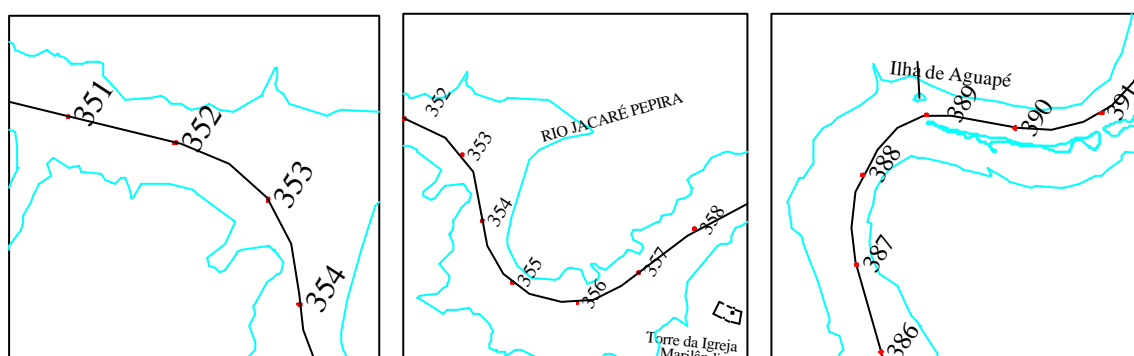

Figura B.37 – Raios de Curvatura dos Pontos Kilométricos 406,5-408, 414-416 e 424-425

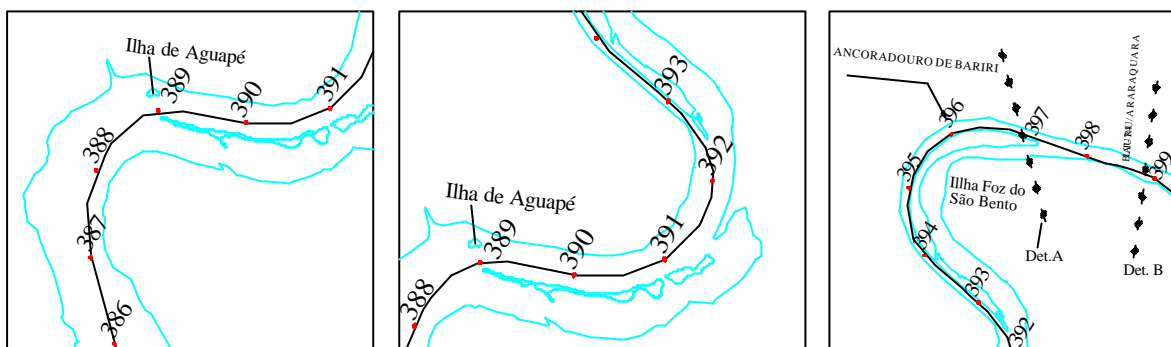

F

Figura B.38 – Raios de Curvatura dos Pontos Kilométricos 488-490, 504-505 e 515-516

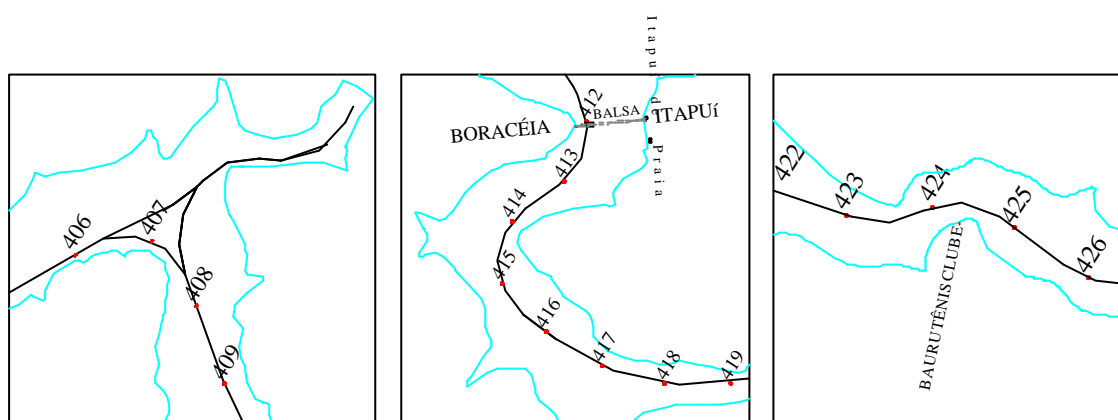
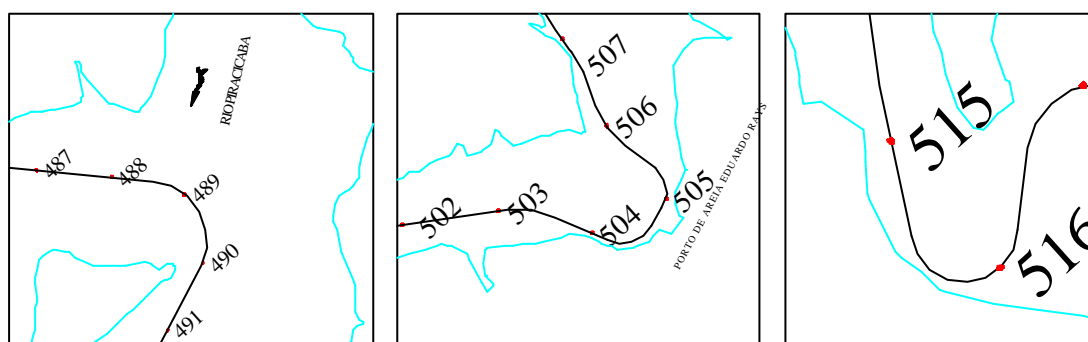

Figura B.39 – Raios de Curvatura dos Pontos Kilométricos 516-517, 520-521 e 523-525



Figura B.40 – Raios de Curvatura dos Pontos Kilométricos 527-528, 531-532 e 532,5-533

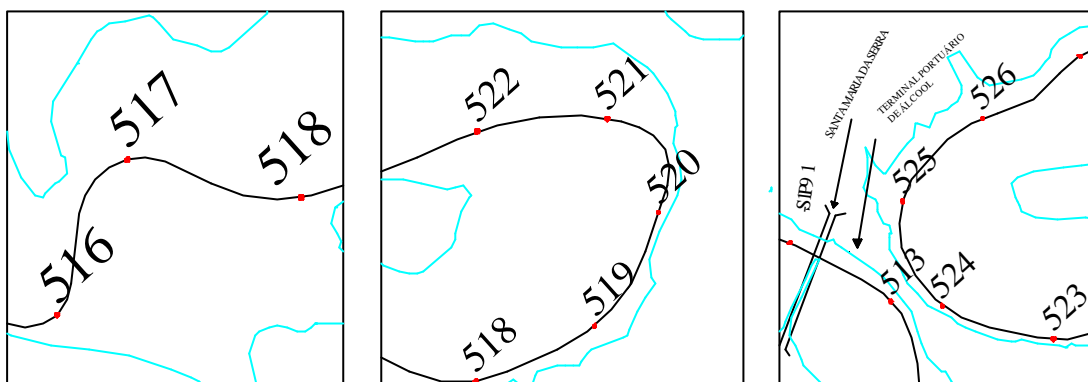

Figura B.41 – Raios de Curvatura dos Pontos Kilométricos 538-540, 543-545 e 547-549

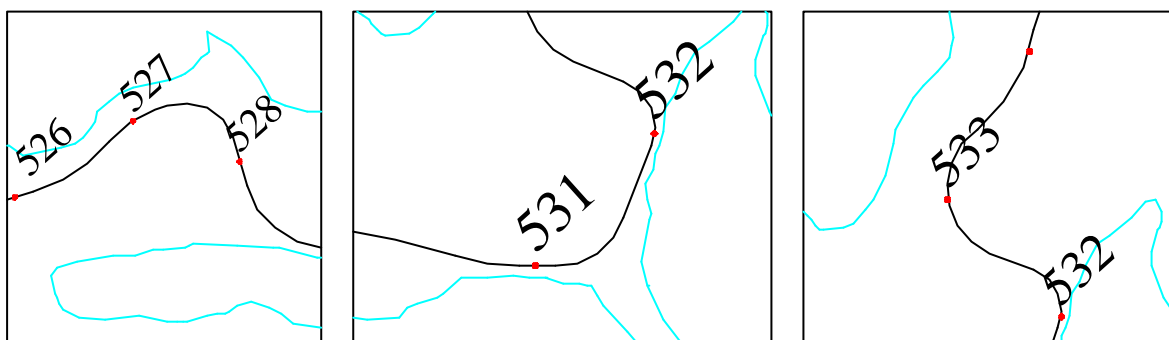

Figura B.42 – Raios de Curvatura dos Pontos Kilométricos 553-555, 556,5-558 e 558-559

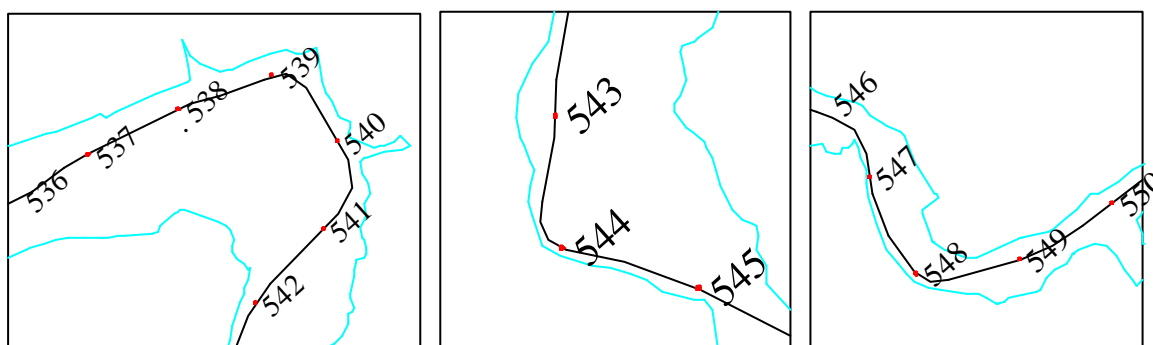

Figura B. 43 – Raios de Curvatura dos Pontos Kilométricos 559-560, 562-563 e 564-565



Figura B.44 – Raios de Curvatura dos Pontos Kilométricos 566-567 e 569-570

Raios de Curvatura do Rio Paraná

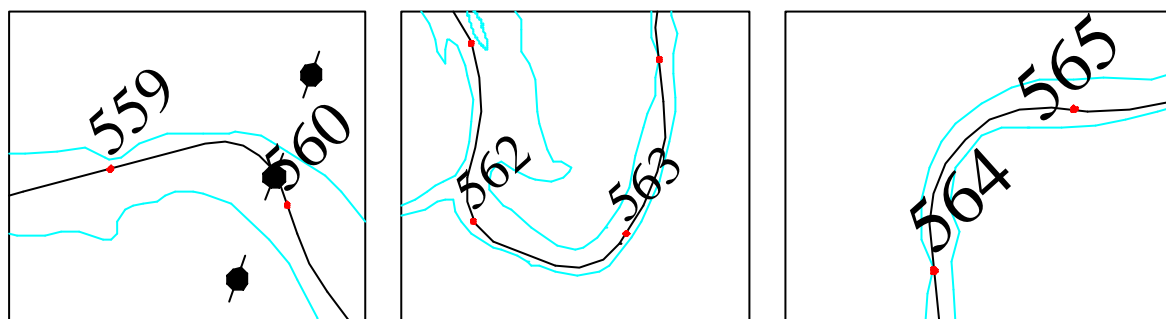

Figura B.45 – Raios de Curvatura dos Pontos Kilométricos 2257-2260, 2292-2294 e 2490-2494

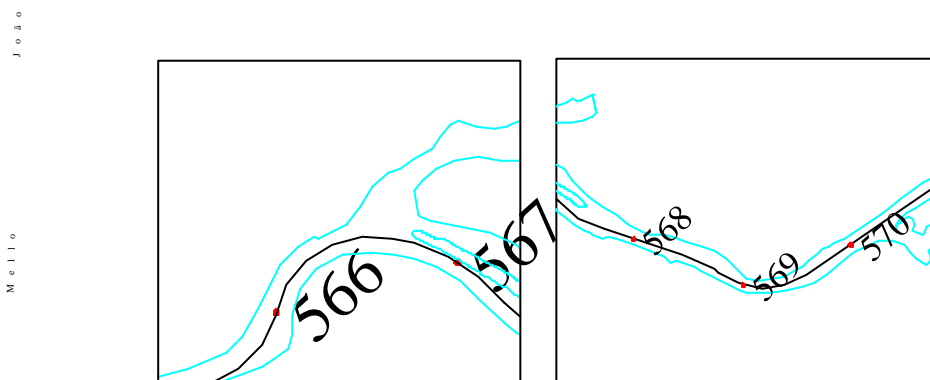

Figura B.46 – Raios de Curvatura dos Pontos Kilométricos 2501-2505 e 2566-2568

Raios de Curvatura do Rio Paranaíba

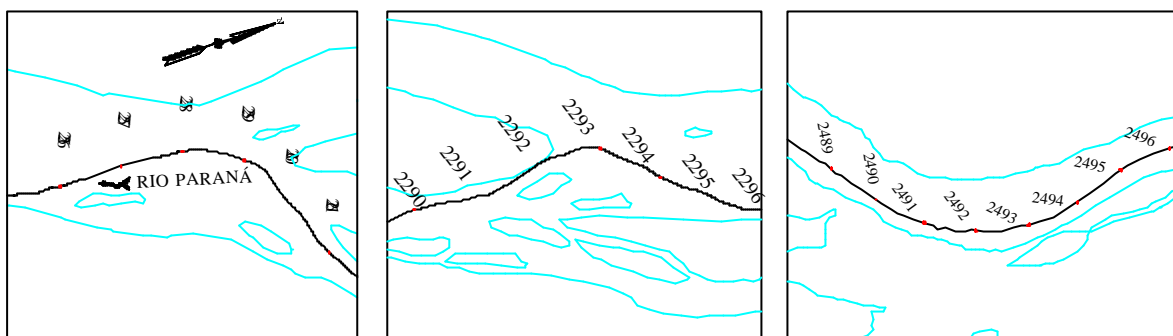

Figura B.47 – Raios de Curvatura dos Pontos Kilométricos 74-80, 88-95 e 121-123

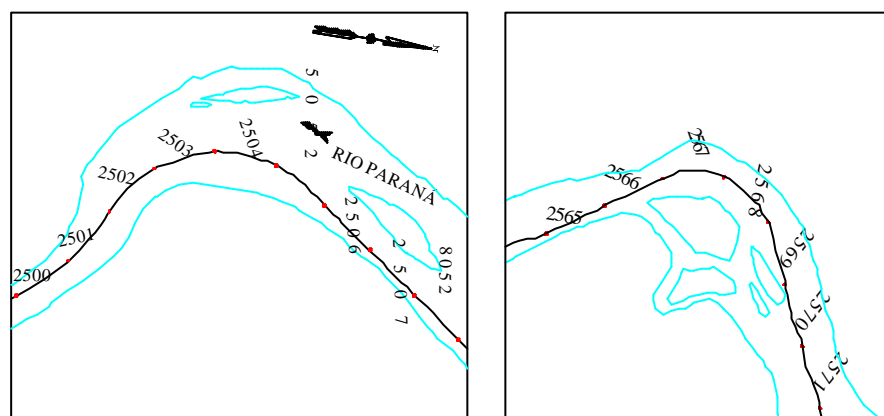

Figura B.48 – Raios de Curvatura dos Pontos Kilométricos 139-141 e 142-144

Canais Artificiais da Hidrovia Tietê-Paraná

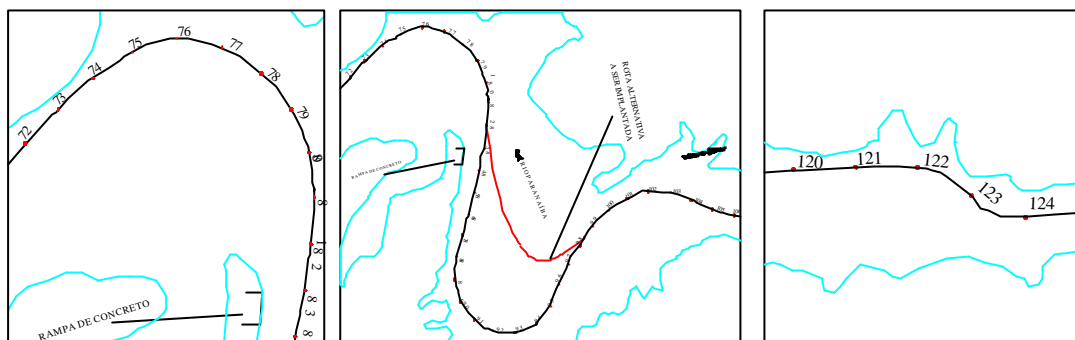

Figura B.49 – Canal de Pereira Barreto

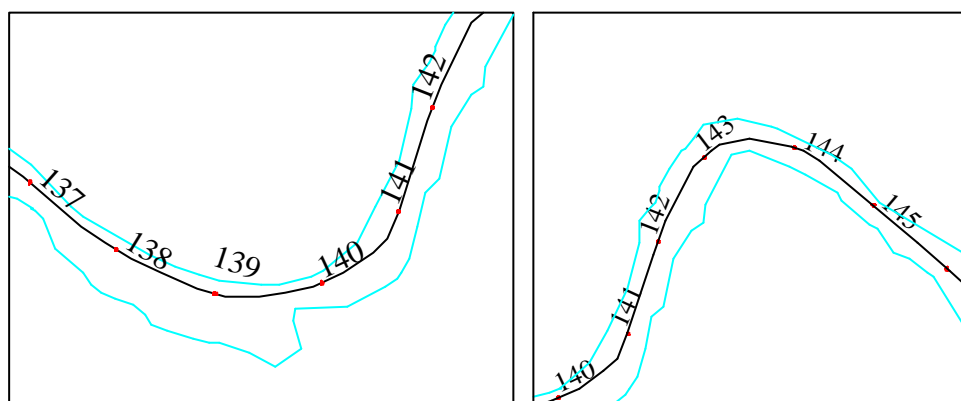

Figura B.50 – Canal de Bariri

Gasoduto Brasil - Bolívia

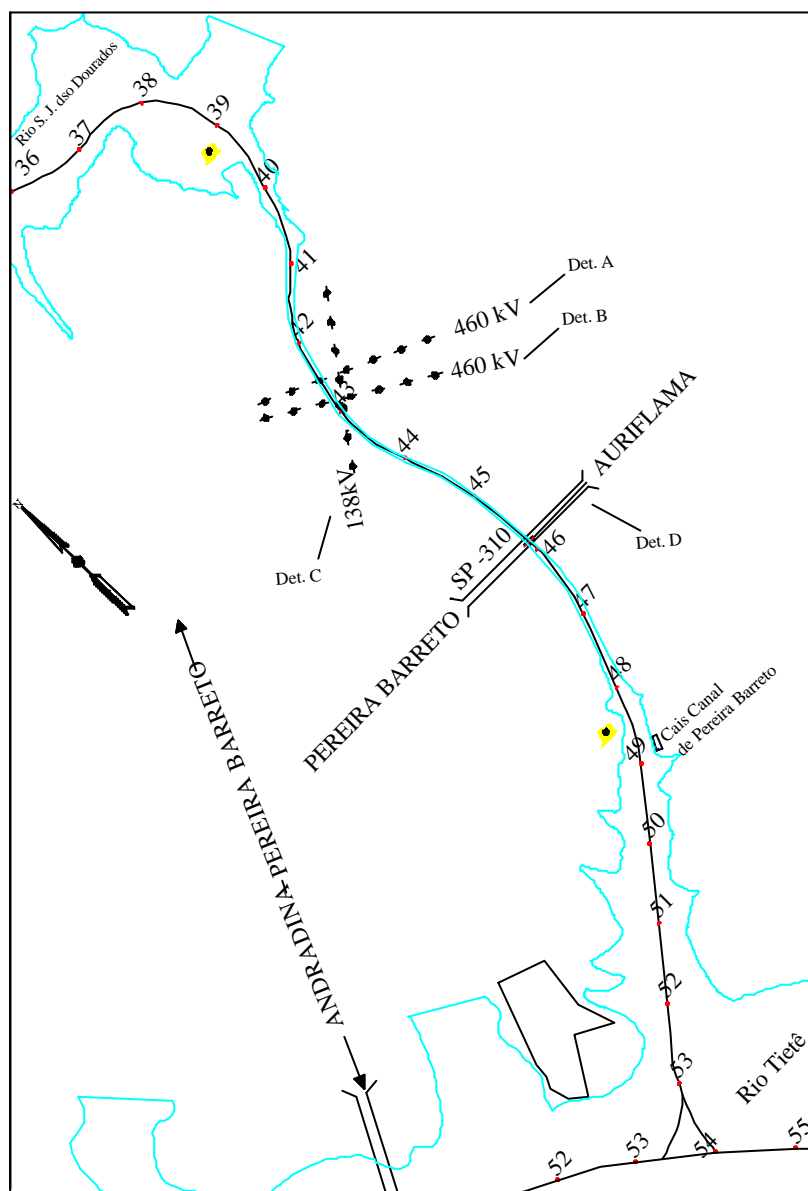
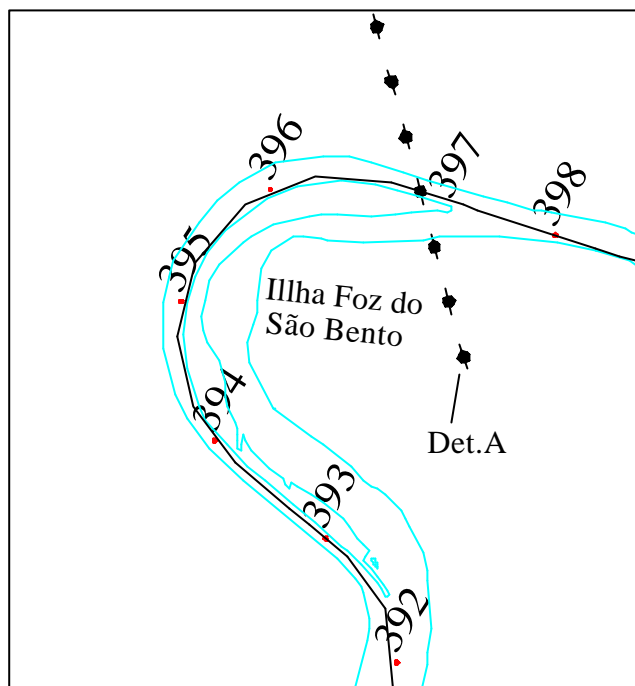
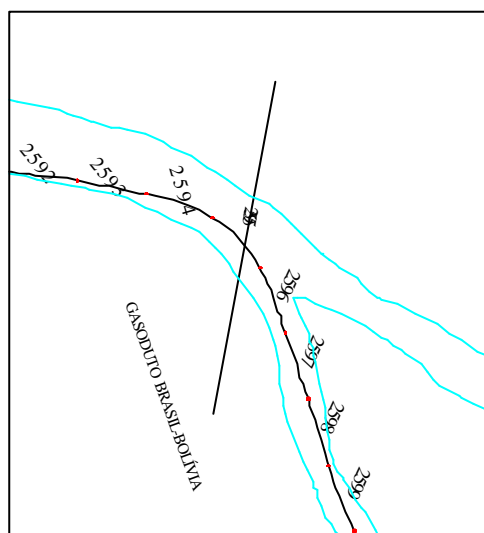

Figura B.51 – Gasoduto Brasil-Bolívia